

TL082 Wide Bandwidth Dual JFET Input Operational Amplifier

Check for Samples: [TL082-N](#)

FEATURES

- Internally Trimmed Offset Voltage: 15 mV
- Low Input Bias Current: 50 pA
- Low Input Noise Voltage: 16nV/√Hz
- Low Input Noise Current: 0.01 pA/√Hz
- Wide Gain Bandwidth: 4 MHz
- High Slew Rate: 13 V/μs
- Low Supply Current: 3.6 mA
- High Input Impedance: 10¹²Ω
- Low Total Harmonic Distortion: ≤0.02%
- Low 1/f Noise Corner: 50 Hz
- Fast Settling Time to 0.01%: 2 μs

DESCRIPTION

These devices are low cost, high speed, dual JFET input operational amplifiers with an internally trimmed input offset voltage (BI-FET II™ technology). They require low supply current yet maintain a large gain bandwidth product and fast slew rate. In addition, well matched high voltage JFET input devices provide very low input bias and offset currents. The TL082 is pin compatible with the standard LM1558 allowing designers to immediately upgrade the overall performance of existing LM1558 and most LM358 designs.

These amplifiers may be used in applications such as high speed integrators, fast D/A converters, sample and hold circuits and many other circuits requiring low input offset voltage, low input bias current, high input impedance, high slew rate and wide bandwidth. The devices also exhibit low noise and offset voltage drift.

Typical Connection

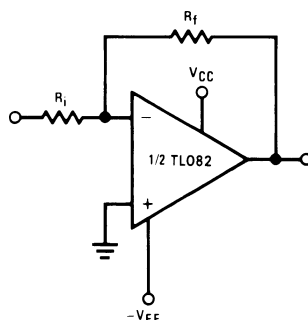

Connection Diagram

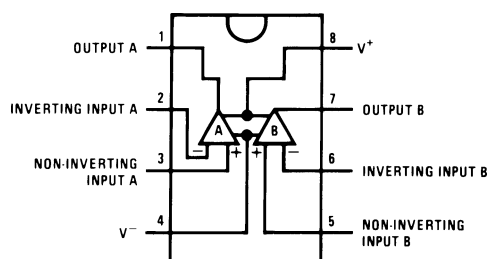

Figure 1. PDIP/SOIC Package (Top View)
See Package Number D0008A or P0008E



Please be aware that an important notice concerning availability, standard warranty, and use in critical applications of Texas Instruments semiconductor products and disclaimers thereto appears at the end of this data sheet.

BI-FET II is a trademark of dcl_owner.

All other trademarks are the property of their respective owners.

Simplified Schematic

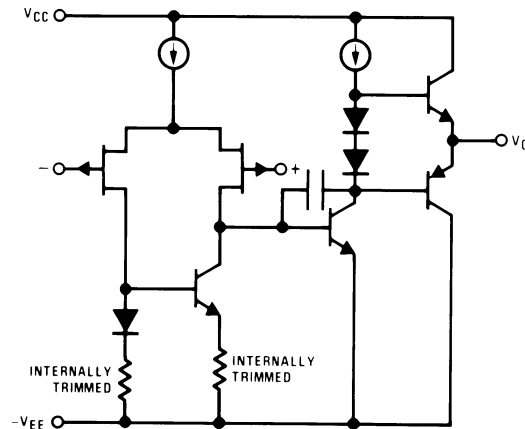

These devices have limited built-in ESD protection. The leads should be shorted together or the device placed in conductive foam during storage or handling to prevent electrostatic damage to the MOS gates.

Absolute Maximum Ratings ⁽¹⁾⁽²⁾

Supply Voltage	±18V
Power Dissipation ⁽³⁾	⁽⁴⁾
Operating Temperature Range	0°C to +70°C
T _{j(MAX)}	150°C
Differential Input Voltage	±30V
Input Voltage Range ⁽⁵⁾	±15V
Output Short Circuit Duration	Continuous
Storage Temperature Range	-65°C to +150°C
Lead Temp. (Soldering, 10 seconds)	260°C
ESD rating to be determined.	

- (1) "Absolute Maximum Ratings" indicate limits beyond which damage to the device may occur. Operating Ratings indicate conditions for which the device is functional, but do not ensure specific performance limits.
- (2) If Military/Aerospace specified devices are required, please contact the Texas Instruments Sales Office/ Distributors for availability and specifications.
- (3) The power dissipation limit, however, cannot be exceeded.
- (4) For operating at elevated temperature, the device must be derated based on a thermal resistance of 115°C/W junction to ambient for the P0008E package.
- (5) Unless otherwise specified the absolute maximum negative input voltage is equal to the negative power supply voltage.

DC Electrical Characteristics ⁽¹⁾

Symbol	Parameter	Conditions	TL082C			Units
			Min	Typ	Max	
V_{OS}	Input Offset Voltage	$R_S = 10\text{ k}\Omega$, $T_A = 25^\circ\text{C}$ Over Temperature		5	15 20	mV mV
$\Delta V_{OS}/\Delta T$	Average TC of Input Offset Voltage	$R_S = 10\text{ k}\Omega$		10		$\mu\text{V}/^\circ\text{C}$
I_{OS}	Input Offset Current	$T_j = 25^\circ\text{C}$, ⁽¹⁾ ⁽²⁾ $T_j \leq 70^\circ\text{C}$		25	200 4	pA nA
I_B	Input Bias Current	$T_j = 25^\circ\text{C}$, ⁽¹⁾ ⁽²⁾ $T_j \leq 70^\circ\text{C}$		50	400 8	pA nA
R_{IN}	Input Resistance	$T_j = 25^\circ\text{C}$		10^{12}		Ω
A_{VOL}	Large Signal Voltage Gain	$V_S = \pm 15\text{V}$, $T_A = 25^\circ\text{C}$, $V_O = \pm 10\text{V}$, $R_L = 2\text{ k}\Omega$ Over Temperature	25 15	100		V/mV V/mV
V_O	Output Voltage Swing	$V_S = \pm 15\text{V}$, $R_L = 10\text{ k}\Omega$	± 12	± 13.5		V
V_{CM}	Input Common-Mode Voltage Range	$V_S = \pm 15\text{V}$	± 11	+15 -12		V V
CMRR	Common-Mode Rejection Ratio	$R_S \leq 10\text{ k}\Omega$	70	100		dB
PSRR	Supply Voltage Rejection Ratio	⁽³⁾	70	100		dB
I_S	Supply Current			3.6	5.6	mA

- (1) These specifications apply for $V_S = \pm 15\text{V}$ and $0^\circ\text{C} \leq T_A \leq +70^\circ\text{C}$. V_{OS} , I_B and I_{OS} are measured at $V_{CM} = 0$.
- (2) The input bias currents are junction leakage currents which approximately double for every 10°C increase in the junction temperature, T_j . Due to the limited production test time, the input bias currents measured are correlated to junction temperature. In normal operation the junction temperature rises above the ambient temperature as a result of internal power dissipation, P_D . $T_j = T_A + \theta_{JA} P_D$ where θ_{JA} is the thermal resistance from junction to ambient. Use of a heat sink is recommended if input bias current is to be kept to a minimum.
- (3) Supply voltage rejection ratio is measured for both supply magnitudes increasing or decreasing simultaneously in accordance with common practice. $V_S = \pm 6\text{V}$ to $\pm 15\text{V}$.

AC Electrical Characteristics ⁽¹⁾

Symbol	Parameter	Conditions	TL082C			Units
			Min	Typ	Max	
	Amplifier to Amplifier Coupling	$T_A = 25^\circ\text{C}$, $f = 1\text{ Hz} - 20\text{ kHz}$ (Input Referred)		-120		dB
SR	Slew Rate	$V_S = \pm 15\text{V}$, $T_A = 25^\circ\text{C}$	8	13		V/ μs
GBW	Gain Bandwidth Product	$V_S = \pm 15\text{V}$, $T_A = 25^\circ\text{C}$		4		MHz
e_n	Equivalent Input Noise Voltage	$T_A = 25^\circ\text{C}$, $R_S = 100\Omega$, $f = 1000\text{ Hz}$		25		nV/ $\sqrt{\text{Hz}}$
i_n	Equivalent Input Noise Current	$T_j = 25^\circ\text{C}$, $f = 1000\text{ Hz}$		0.01		pA/ $\sqrt{\text{Hz}}$
THD	Total Harmonic Distortion	$A_V = +10$, $R_L = 10\text{k}$, $V_O = 20\text{ V}_p - p$, $\text{BW} = 20\text{ Hz} - 20\text{ kHz}$		<0.02		%

- (1) These specifications apply for $V_S = \pm 15\text{V}$ and $0^\circ\text{C} \leq T_A \leq +70^\circ\text{C}$. V_{OS} , I_B and I_{OS} are measured at $V_{CM} = 0$.

Typical Performance Characteristics

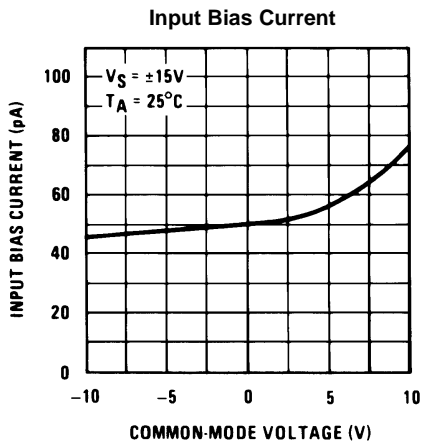

Figure 2.

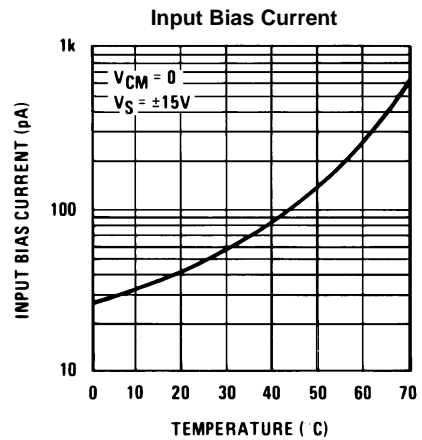

Figure 3.

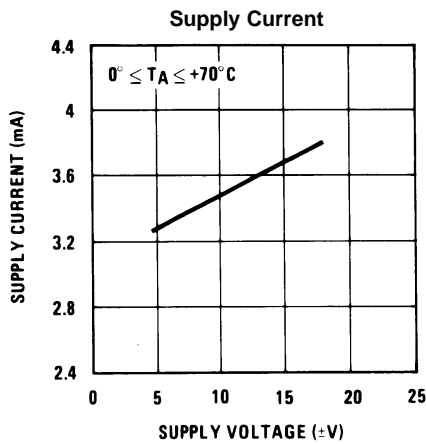

Figure 4.

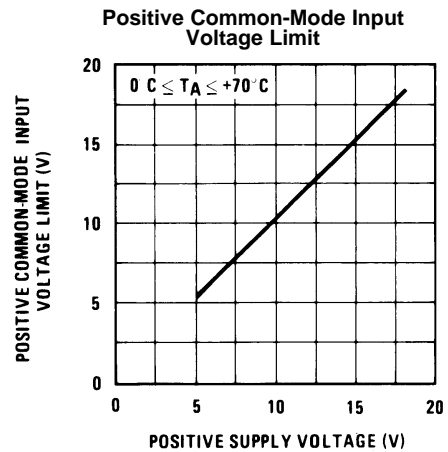

Figure 5.

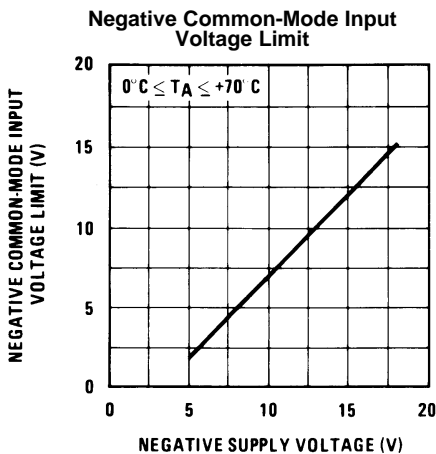

Figure 6.

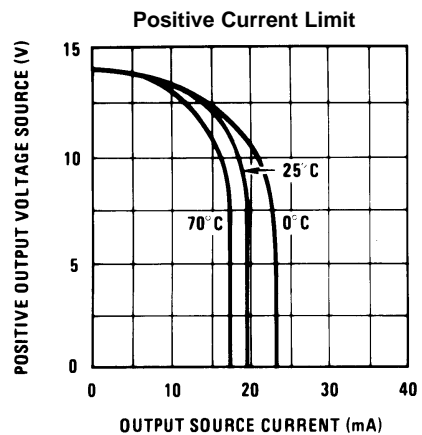

Figure 7.

Typical Performance Characteristics (continued)

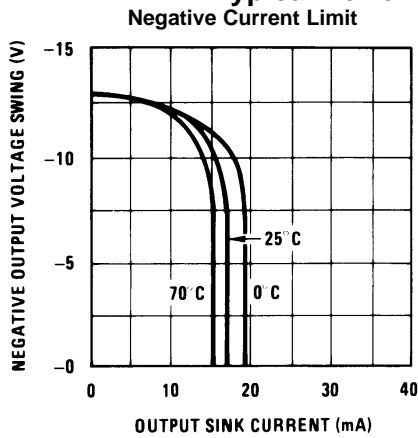

Figure 8.

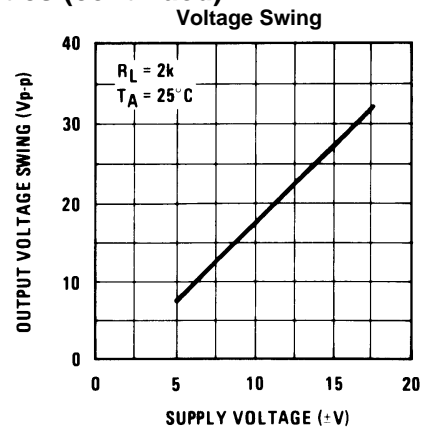

Figure 9.

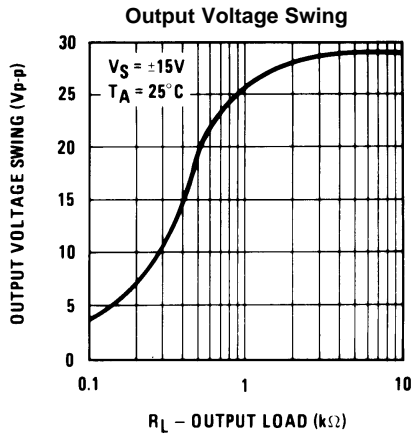

Figure 10.

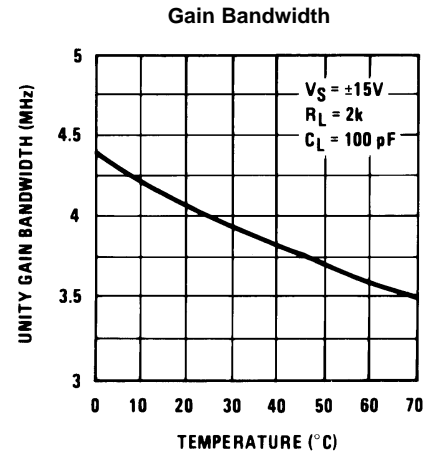

Figure 11.

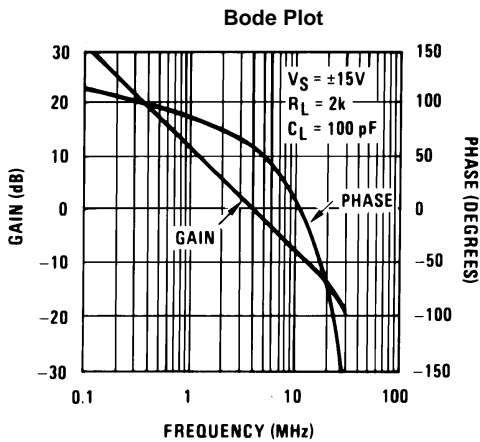

Figure 12.

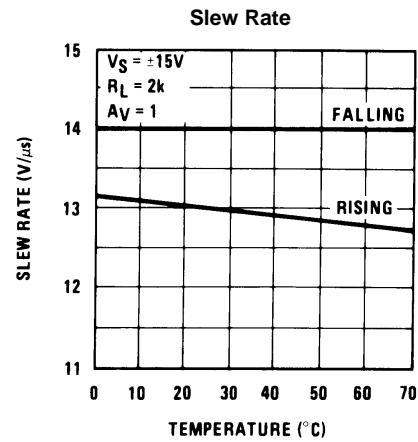
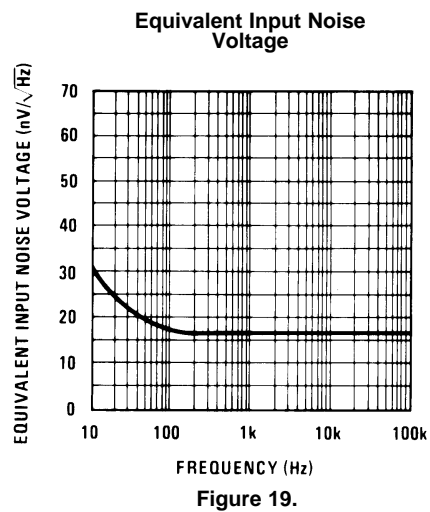
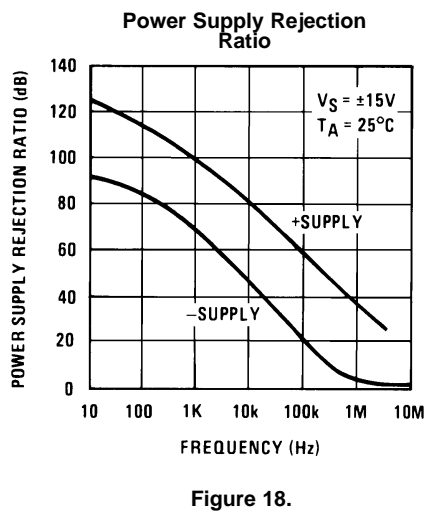
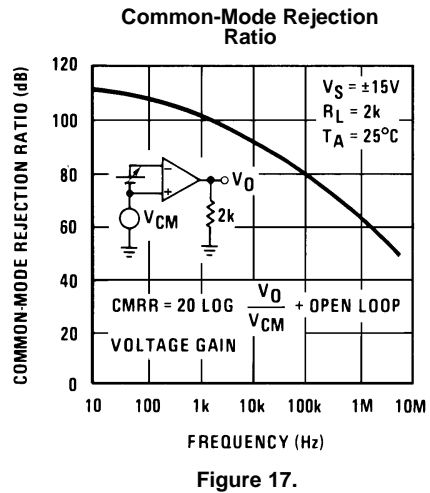
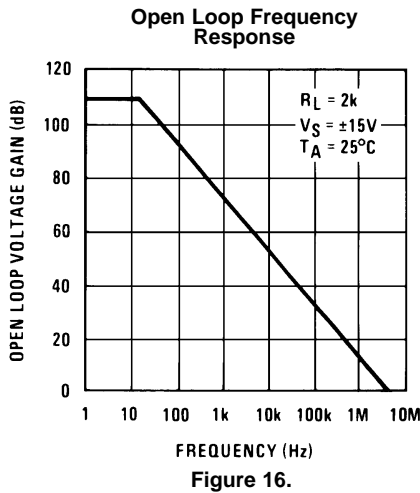
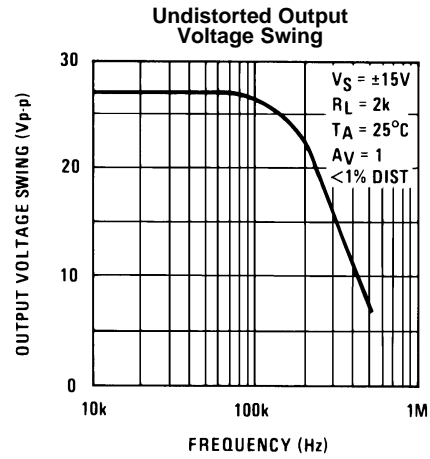
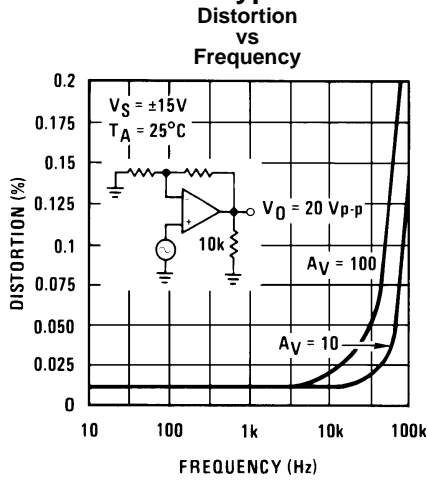

Figure 13.

Typical Performance Characteristics (continued)



Typical Performance Characteristics (continued)

Open Loop Voltage Gain (V/V)

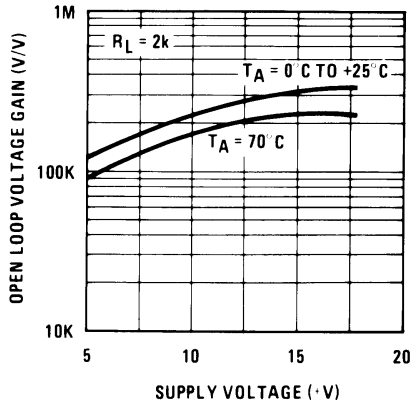

Figure 20.

Output Impedance

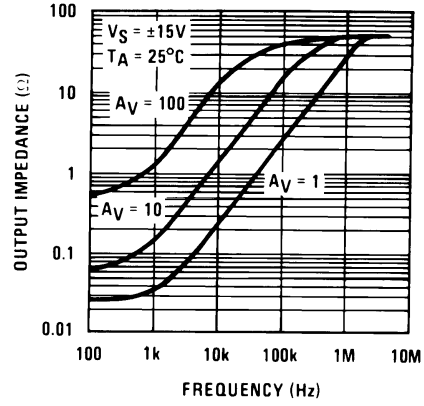

Figure 21.

Inverter Setting Time

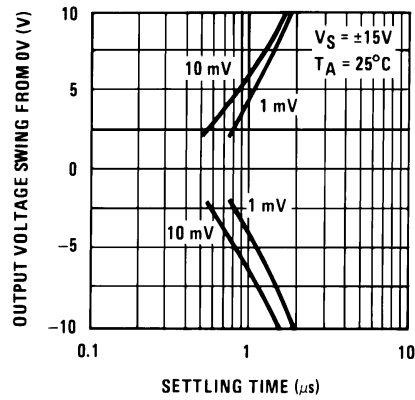
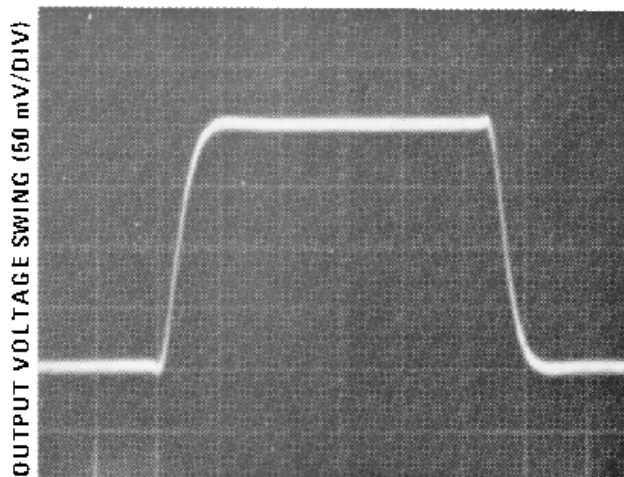

Figure 22.

Pulse Response

Small Signal Inverting



TIME (0.2 μ s/DIV)

Figure 23.

Large Signal Inverting

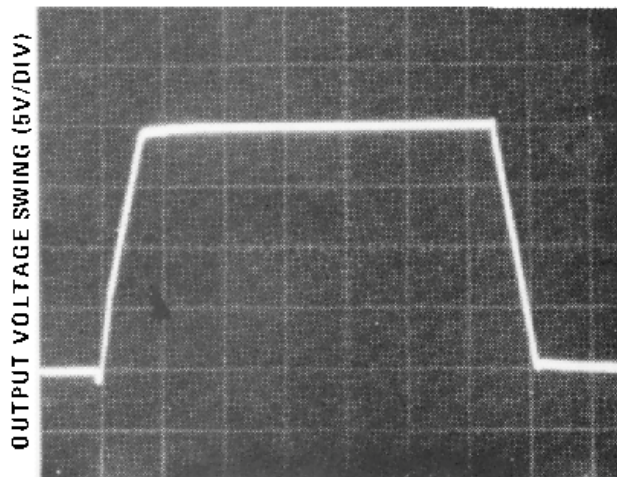

TIME (2 μ s/DIV)

Figure 24.

Small Signal Non-Inverting

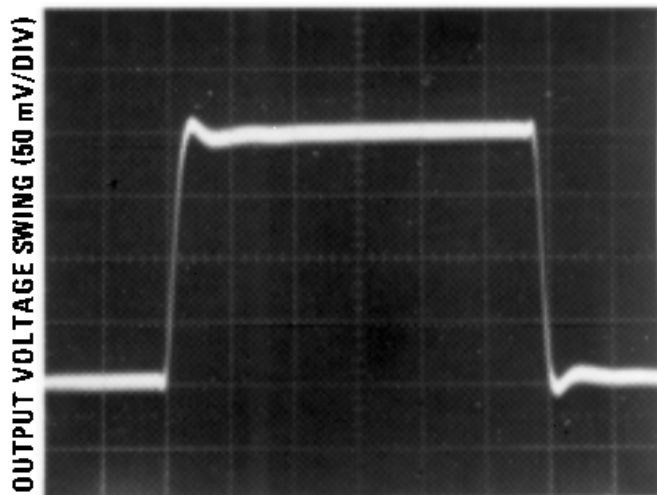

TIME (0.2 μ s/DIV)

Figure 25.

Large Signal Non-Inverting

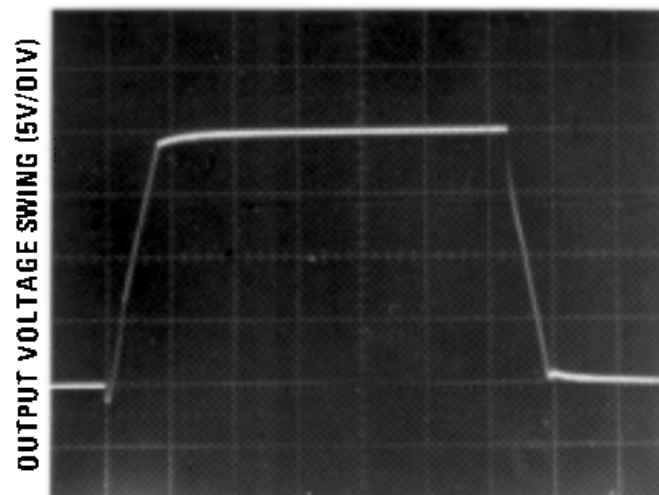

TIME (2 μ s/DIV)

Figure 26.

Pulse Response (continued)
Current Limit ($R_L = 100\Omega$)

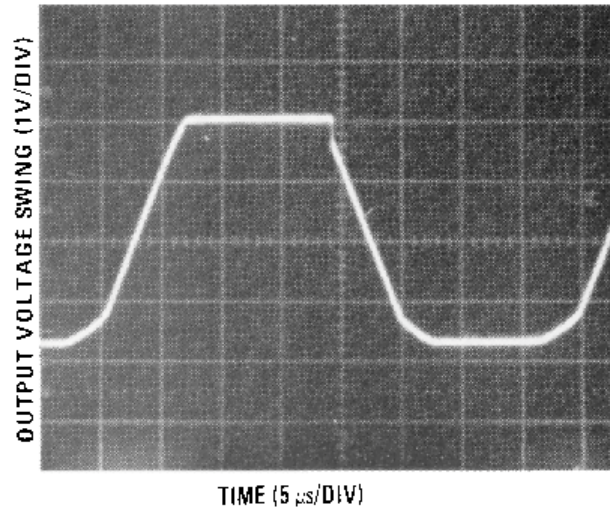

Figure 27.

APPLICATION HINTS

These devices are op amps with an internally trimmed input offset voltage and JFET input devices (BI-FET II). These JFETs have large reverse breakdown voltages from gate to source and drain eliminating the need for clamps across the inputs. Therefore, large differential input voltages can easily be accommodated without a large increase in input current. The maximum differential input voltage is independent of the supply voltages. However, neither of the input voltages should be allowed to exceed the negative supply as this will cause large currents to flow which can result in a destroyed unit.

Exceeding the negative common-mode limit on either input will cause a reversal of the phase to the output and force the amplifier output to the corresponding high or low state. Exceeding the negative common-mode limit on both inputs will force the amplifier output to a high state. In neither case does a latch occur since raising the input back within the common-mode range again puts the input stage and thus the amplifier in a normal operating mode.

Exceeding the positive common-mode limit on a single input will not change the phase of the output; however, if both inputs exceed the limit, the output of the amplifier will be forced to a high state.

The amplifiers will operate with a common-mode input voltage equal to the positive supply; however, the gain bandwidth and slew rate may be decreased in this condition. When the negative common-mode voltage swings to within 3V of the negative supply, an increase in input offset voltage may occur.

Each amplifier is individually biased by a zener reference which allows normal circuit operation on $\pm 6V$ power supplies. Supply voltages less than these may result in lower gain bandwidth and slew rate.

The amplifiers will drive a 2 k Ω load resistance to $\pm 10V$ over the full temperature range of 0°C to +70°C. If the amplifier is forced to drive heavier load currents, however, an increase in input offset voltage may occur on the negative voltage swing and finally reach an active current limit on both positive and negative swings.

Precautions should be taken to ensure that the power supply for the integrated circuit never becomes reversed in polarity or that the unit is not inadvertently installed backwards in a socket as an unlimited current surge through the resulting forward diode within the IC could cause fusing of the internal conductors and result in a destroyed unit.

Because these amplifiers are JFET rather than MOSFET input op amps they do not require special handling.

As with most amplifiers, care should be taken with lead dress, component placement and supply decoupling in order to ensure stability. For example, resistors from the output to an input should be placed with the body close to the input to minimize “pick-up” and maximize the frequency of the feedback pole by minimizing the capacitance from the input to ground.

A feedback pole is created when the feedback around any amplifier is resistive. The parallel resistance and capacitance from the input of the device (usually the inverting input) to AC ground set the frequency of the pole. In many instances the frequency of this pole is much greater than the expected 3 dB frequency of the closed loop gain and consequently there is negligible effect on stability margin. However, if the feedback pole is less than approximately 6 times the expected 3 dB frequency a lead capacitor should be placed from the output to the input of the op amp. The value of the added capacitor should be such that the RC time constant of this capacitor and the resistance it parallels is greater than or equal to the original feedback pole time constant.

Detailed Schematic

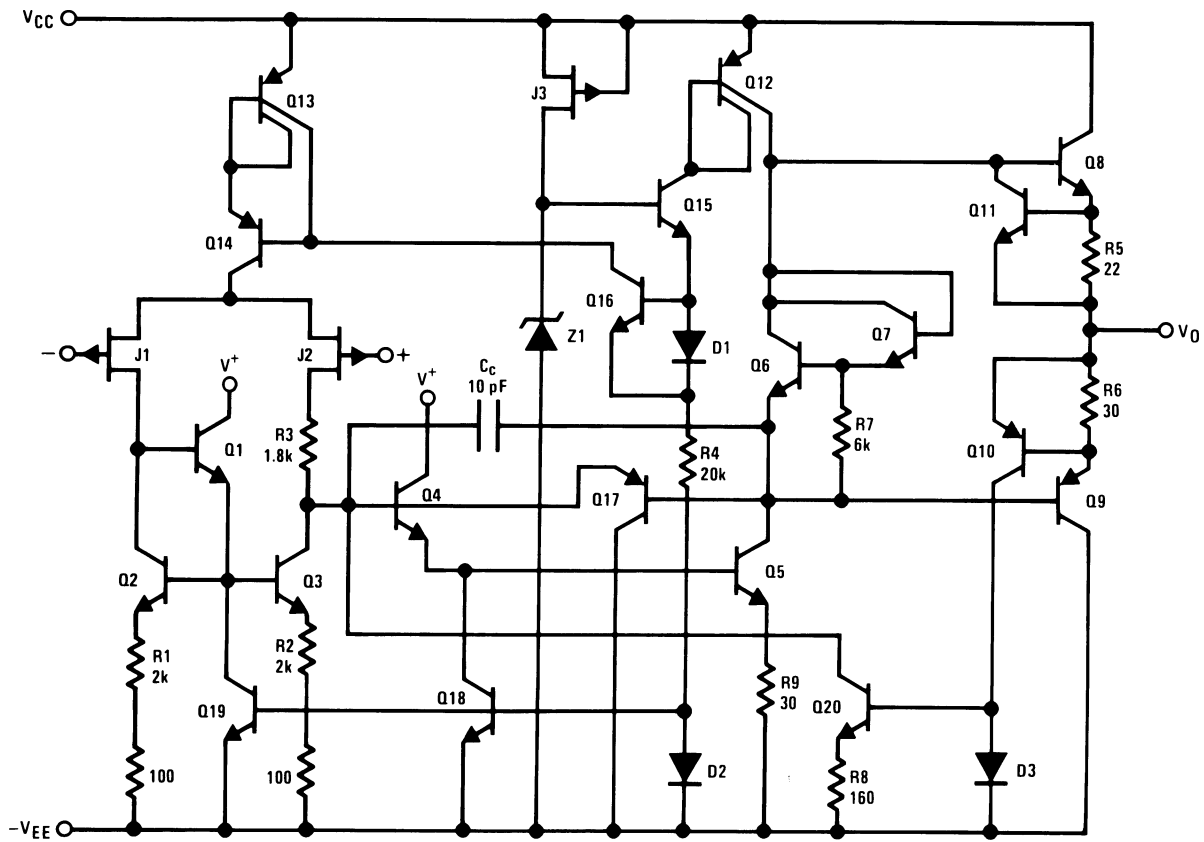

Typical Applications

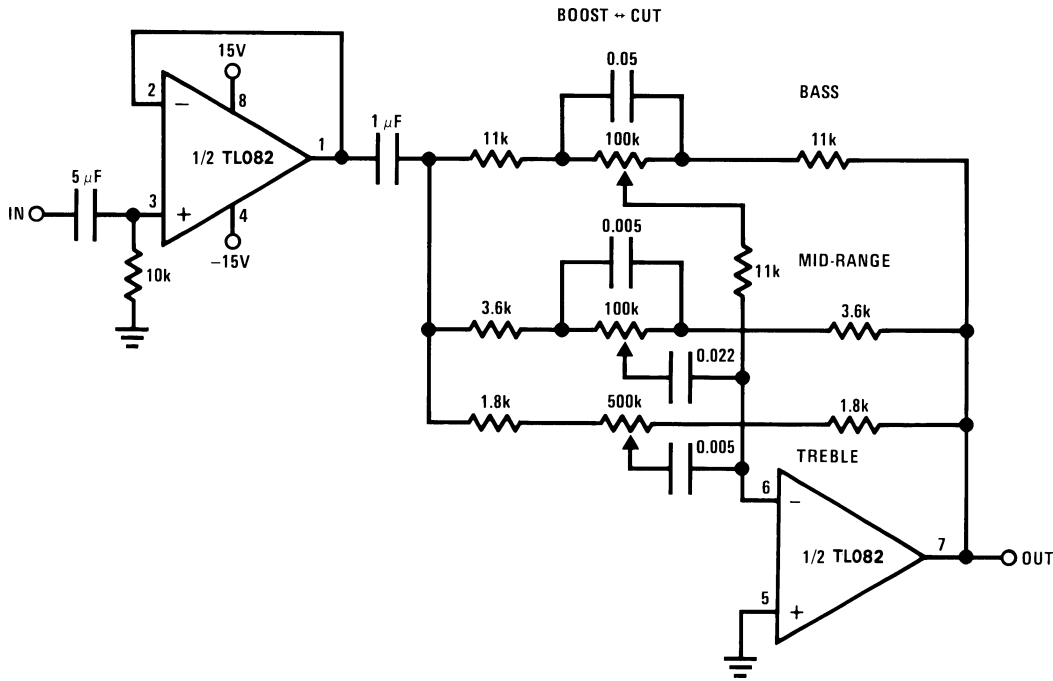

- All potentiometers are linear taper
- Use the LF347 Quad for stereo applications

All controls flat.

Bass and treble boost, mid flat.

Bass and treble cut, mid flat.

Mid boost, bass and treble flat.

Mid cut, bass and treble flat.

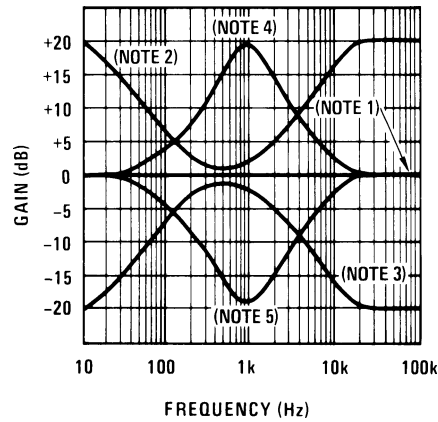
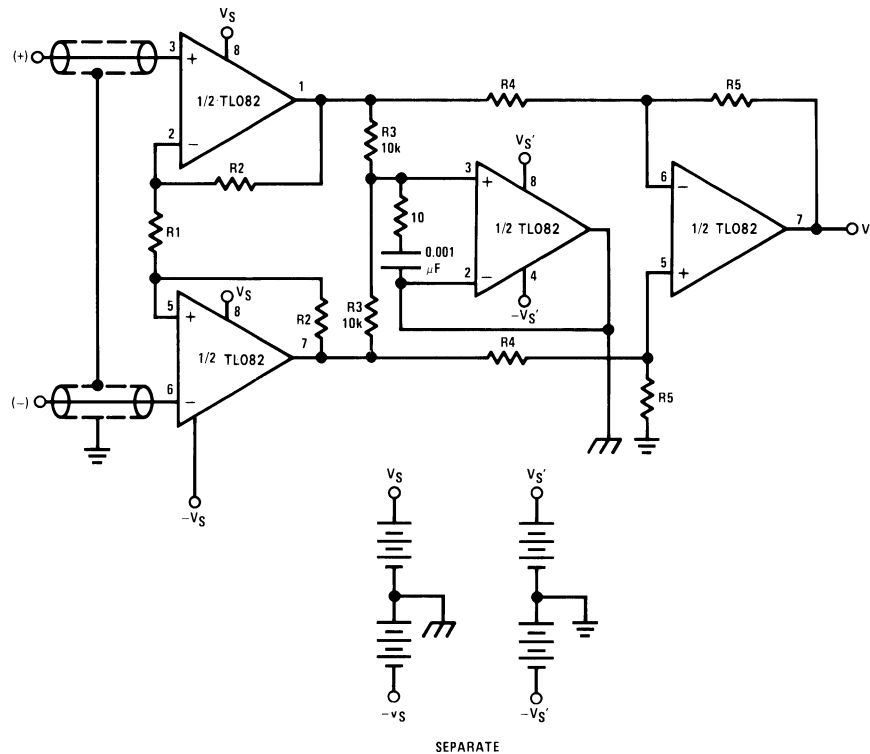

Figure 28. Three-Band Active Tone Control



$$A_v = \left(\frac{2R_2}{R_1} + 1 \right) \frac{R_5}{R_4}$$

and are separate isolated grounds

Matching of R2's, R4's and R5's control CMRR

With $A_{VT} = 1400$, resistor matching = 0.01%: CMRR = 136 dB

- Very high input impedance
- Super high CMRR

Figure 29. Improved CMRR Instrumentation Amplifier

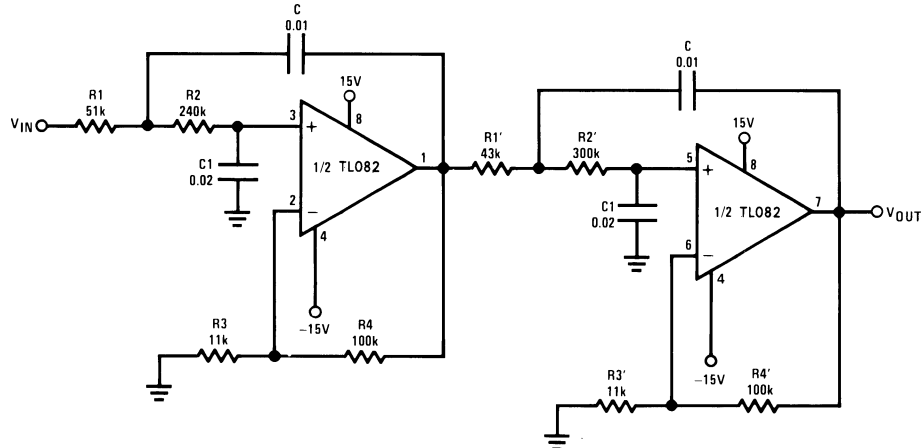

- Corner frequency (f_c) = $\sqrt{\frac{1}{R_1 R_2 C C_1}} \cdot \frac{1}{2\pi} = \sqrt{\frac{1}{R_1' R_2' C C_1}} \cdot \frac{1}{2\pi}$
- Passband gain (H_0) = $(1 + R_4/R_3) (1 + R_4'/R_3')$
- First stage Q = 1.31
- Second stage Q = 0.541
- Circuit shown uses nearest 5% tolerance resistor values for a filter with a corner frequency of 100 Hz and a passband gain of 100
- Offset nulling necessary for accurate DC performance

Figure 30. Fourth Order Low Pass Butterworth Filter

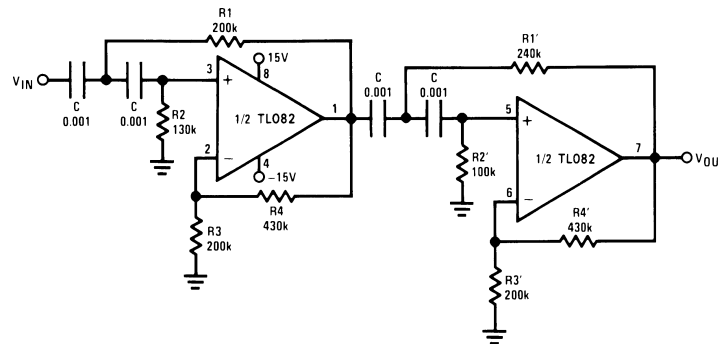

- Corner frequency (f_c) = $\sqrt{\frac{1}{R_1 R_2 C^2}} \cdot \frac{1}{2\pi} = \sqrt{\frac{1}{R_1' R_2' C^2}} \cdot \frac{1}{2\pi}$
- Passband gain (H_0) = $(1 + R_4/R_3) (1 + R_4'/R_3')$
- First stage Q = 1.31
- Second stage Q = 0.541
- Circuit shown uses closest 5% tolerance resistor values for a filter with a corner frequency of 1 kHz and a passband gain of 10

Figure 31. Fourth Order High Pass Butterworth Filter

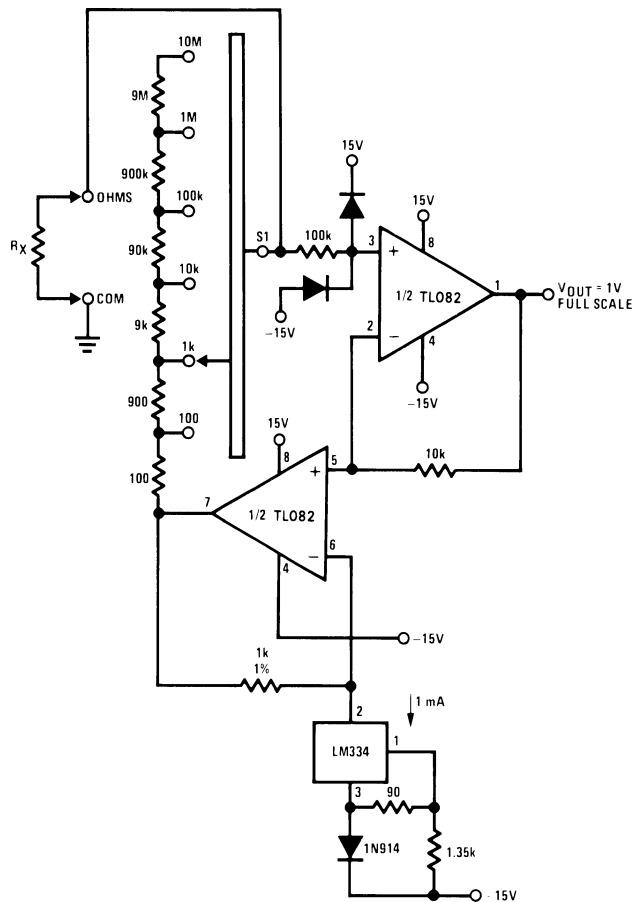

$$V_O = \frac{1V}{R_{LADDER}} \times R_X$$

Where R_{LADDER} is the resistance from switch S1 pole to pin 7 of the TL082CP.

Figure 32. Ohms to Volts Converter

REVISION HISTORY

Changes from Revision B (April 2013) to Revision C	Page
• Changed layout of National Data Sheet to TI format	15

PACKAGING INFORMATION

Orderable part number	Status (1)	Material type (2)	Package Pins	Package qty Carrier	RoHS (3)	Lead finish/ Ball material (4)	MSL rating/ Peak reflow (5)	Op temp (°C)	Part marking (6)
TL082CM/NOPB	Active	Production	SOIC (D) 8	95 TUBE	Yes	SN	Level-1-260C-UNLIM	0 to 70	TL 082CM
TL082CM/NOPB.B	Active	Production	SOIC (D) 8	95 TUBE	Yes	SN	Level-1-260C-UNLIM	0 to 70	TL 082CM
TL082CMX/NOPB	Active	Production	SOIC (D) 8	2500 LARGE T&R	Yes	SN	Level-1-260C-UNLIM	0 to 70	TL 082CM
TL082CMX/NOPB.B	Active	Production	SOIC (D) 8	2500 LARGE T&R	Yes	SN	Level-1-260C-UNLIM	0 to 70	TL 082CM
TL082CP/NOPB	Active	Production	PDIP (P) 8	40 TUBE	Yes	NIPDAU	Level-1-NA-UNLIM	0 to 70	TL082 CP
TL082CP/NOPB.B	Active	Production	PDIP (P) 8	40 TUBE	Yes	NIPDAU	Level-1-NA-UNLIM	0 to 70	TL082 CP

(1) **Status:** For more details on status, see our [product life cycle](#).

(2) **Material type:** When designated, preproduction parts are prototypes/experimental devices, and are not yet approved or released for full production. Testing and final process, including without limitation quality assurance, reliability performance testing, and/or process qualification, may not yet be complete, and this item is subject to further changes or possible discontinuation. If available for ordering, purchases will be subject to an additional waiver at checkout, and are intended for early internal evaluation purposes only. These items are sold without warranties of any kind.

(3) **RoHS values:** Yes, No, RoHS Exempt. See the [TI RoHS Statement](#) for additional information and value definition.

(4) **Lead finish/Ball material:** Parts may have multiple material finish options. Finish options are separated by a vertical ruled line. Lead finish/Ball material values may wrap to two lines if the finish value exceeds the maximum column width.

(5) **MSL rating/Peak reflow:** The moisture sensitivity level ratings and peak solder (reflow) temperatures. In the event that a part has multiple moisture sensitivity ratings, only the lowest level per JEDEC standards is shown. Refer to the shipping label for the actual reflow temperature that will be used to mount the part to the printed circuit board.

(6) **Part marking:** There may be an additional marking, which relates to the logo, the lot trace code information, or the environmental category of the part.

Multiple part markings will be inside parentheses. Only one part marking contained in parentheses and separated by a "~" will appear on a part. If a line is indented then it is a continuation of the previous line and the two combined represent the entire part marking for that device.

Important Information and Disclaimer: The information provided on this page represents TI's knowledge and belief as of the date that it is provided. TI bases its knowledge and belief on information provided by third parties, and makes no representation or warranty as to the accuracy of such information. Efforts are underway to better integrate information from third parties. TI has taken and continues to take reasonable steps to provide representative and accurate information but may not have conducted destructive testing or chemical analysis on incoming materials and chemicals. TI and TI suppliers consider certain information to be proprietary, and thus CAS numbers and other limited information may not be available for release.

In no event shall TI's liability arising out of such information exceed the total purchase price of the TI part(s) at issue in this document sold by TI to Customer on an annual basis.

OTHER QUALIFIED VERSIONS OF TL082-N :

- Automotive : [TL082-Q1](#)

NOTE: Qualified Version Definitions:

- Automotive - Q100 devices qualified for high-reliability automotive applications targeting zero defects

TAPE AND REEL INFORMATION

QUADRANT ASSIGNMENTS FOR PIN 1 ORIENTATION IN TAPE

*All dimensions are nominal

Device	Package Type	Package Drawing	Pins	SPQ	Reel Diameter (mm)	Reel Width W1 (mm)	A0 (mm)	B0 (mm)	K0 (mm)	P1 (mm)	W (mm)	Pin1 Quadrant
TL082CMX/NOPB	SOIC	D	8	2500	330.0	12.4	6.5	5.4	2.0	8.0	12.0	Q1

TAPE AND REEL BOX DIMENSIONS

*All dimensions are nominal

Device	Package Type	Package Drawing	Pins	SPQ	Length (mm)	Width (mm)	Height (mm)
TL082CMX/NOPB	SOIC	D	8	2500	367.0	367.0	35.0

TUBE

*All dimensions are nominal

Device	Package Name	Package Type	Pins	SPQ	L (mm)	W (mm)	T (μm)	B (mm)
TL082CM/NOPB	D	SOIC	8	95	495	8	4064	3.05
TL082CM/NOPB.B	D	SOIC	8	95	495	8	4064	3.05
TL082CP/NOPB	P	PDIP	8	40	502	14	11938	4.32
TL082CP/NOPB.B	P	PDIP	8	40	502	14	11938	4.32



D0008A

PACKAGE OUTLINE

SOIC - 1.75 mm max height

SMALL OUTLINE INTEGRATED CIRCUIT



4214825/C 02/2019

NOTES:

1. Linear dimensions are in inches [millimeters]. Dimensions in parenthesis are for reference only. Controlling dimensions are in inches. Dimensioning and tolerancing per ASME Y14.5M.
2. This drawing is subject to change without notice.
3. This dimension does not include mold flash, protrusions, or gate burrs. Mold flash, protrusions, or gate burrs shall not exceed .006 [0.15] per side.
4. This dimension does not include interlead flash.
5. Reference JEDEC registration MS-012, variation AA.

EXAMPLE BOARD LAYOUT

D0008A

SOIC - 1.75 mm max height

SMALL OUTLINE INTEGRATED CIRCUIT



LAND PATTERN EXAMPLE
 EXPOSED METAL SHOWN
 SCALE:8X



SOLDER MASK DETAILS

4214825/C 02/2019

NOTES: (continued)

- 6. Publication IPC-7351 may have alternate designs.
- 7. Solder mask tolerances between and around signal pads can vary based on board fabrication site.

EXAMPLE STENCIL DESIGN

D0008A

SOIC - 1.75 mm max height

SMALL OUTLINE INTEGRATED CIRCUIT



SOLDER PASTE EXAMPLE
BASED ON .005 INCH [0.125 MM] THICK STENCIL
SCALE:8X

4214825/C 02/2019

NOTES: (continued)

8. Laser cutting apertures with trapezoidal walls and rounded corners may offer better paste release. IPC-7525 may have alternate design recommendations.
9. Board assembly site may have different recommendations for stencil design.

P (R-PDIP-T8)

PLASTIC DUAL-IN-LINE PACKAGE



- NOTES:
- A. All linear dimensions are in inches (millimeters).
 - B. This drawing is subject to change without notice.
 - C. Falls within JEDEC MS-001 variation BA.

IMPORTANT NOTICE AND DISCLAIMER

TI PROVIDES TECHNICAL AND RELIABILITY DATA (INCLUDING DATA SHEETS), DESIGN RESOURCES (INCLUDING REFERENCE DESIGNS), APPLICATION OR OTHER DESIGN ADVICE, WEB TOOLS, SAFETY INFORMATION, AND OTHER RESOURCES "AS IS" AND WITH ALL FAULTS, AND DISCLAIMS ALL WARRANTIES, EXPRESS AND IMPLIED, INCLUDING WITHOUT LIMITATION ANY IMPLIED WARRANTIES OF MERCHANTABILITY, FITNESS FOR A PARTICULAR PURPOSE OR NON-INFRINGEMENT OF THIRD PARTY INTELLECTUAL PROPERTY RIGHTS.

These resources are intended for skilled developers designing with TI products. You are solely responsible for (1) selecting the appropriate TI products for your application, (2) designing, validating and testing your application, and (3) ensuring your application meets applicable standards, and any other safety, security, regulatory or other requirements.

These resources are subject to change without notice. TI grants you permission to use these resources only for development of an application that uses the TI products described in the resource. Other reproduction and display of these resources is prohibited. No license is granted to any other TI intellectual property right or to any third party intellectual property right. TI disclaims responsibility for, and you will fully indemnify TI and its representatives against, any claims, damages, costs, losses, and liabilities arising out of your use of these resources.

TI's products are provided subject to [TI's Terms of Sale](#) or other applicable terms available either on [ti.com](https://www.ti.com) or provided in conjunction with such TI products. TI's provision of these resources does not expand or otherwise alter TI's applicable warranties or warranty disclaimers for TI products.

TI objects to and rejects any additional or different terms you may have proposed.

Mailing Address: Texas Instruments, Post Office Box 655303, Dallas, Texas 75265

Copyright © 2025, Texas Instruments Incorporated